

ASAM CMP Capture Module Protocol

Bernd Wenzel
Senior Technical Consultant – ASAM e.V.

October 7/8. 2021
München



Initial Situation

Capture Module Protocol

EE development of vehicles requires data recording

- In vehicle communication (LIN, CAN, FlexRay, xBaseT1)
- Sensor data (CAM, LiDAR, Radar)
- Debug data (DLT, ECU internal)
- Reference sensors

Restrictions of actual systems (logger) for data collection

- Low scalability (number and type of Interfaces)
- TIER1 specific interfaces reduces reuse of loggers
- Simultaneously use of different TIER1 measurement in system test vehicle
- Centralized system with high impact on bus physics
- Implement new bus types in existing loggers not possible

The Idea

Capture Module Protocol

Splitting the logging system

- small stand alone components
- Standardize data transport within the measurement network
 - Standardize translation of vehicle bus communication
 - Standardize TIER1 specific ECU/sensor data output

UseCases

- Scalable measurement
- Reusability of components
- Segmentation of large data samples / Packaging of small data samples
- Timestamping
- Controlling
- Message-loss detection
- Scalable physical layer according to the required bandwidth

System Overview

Capture Module Protocol

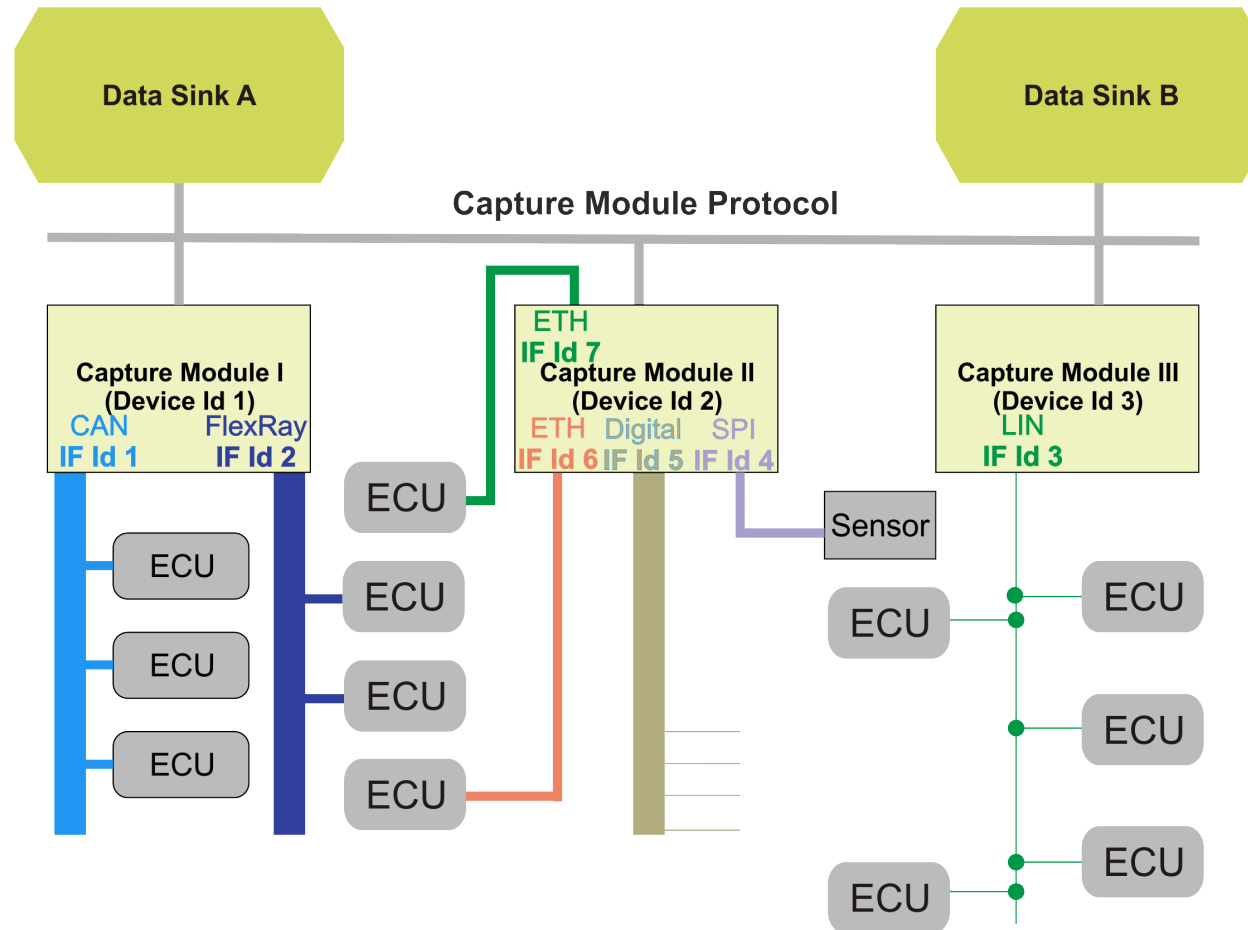

Protocol Basics

Capture Module Protocol

- Transport based on Ethernet MAC Layer (optionally also with UDP)
- Messages dedicated to streams
- Protocol for Time synchronization IEEE 802.1AS-2020
- Segmentation
- Packaging

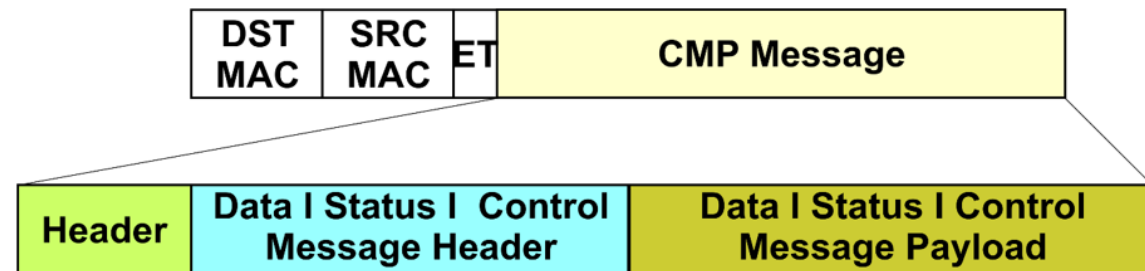
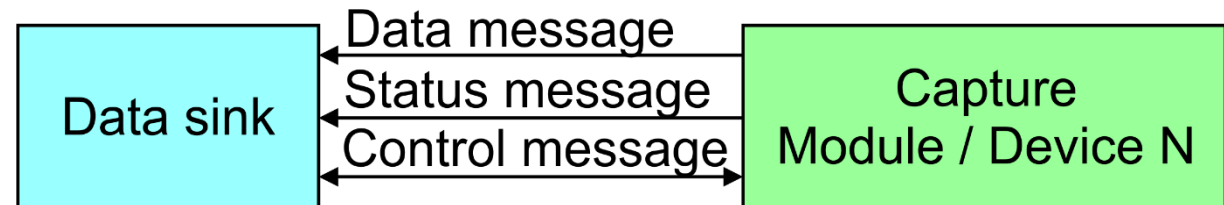

Data message

Capture Module Protocol

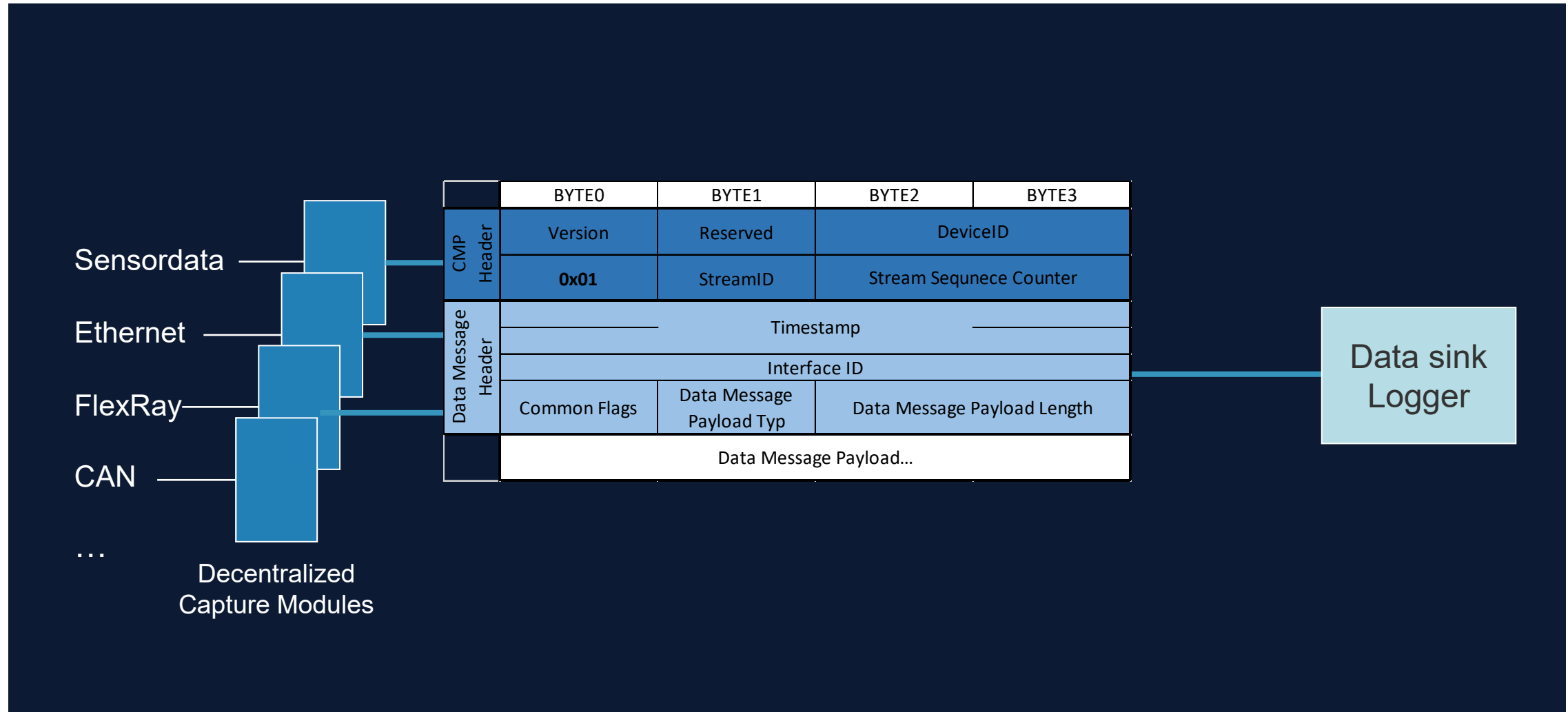

Supported Data Message types

Capture Module Protocol

There will be a variety of Capture Modules and Data sinks (e.g. Loggers) to be supported:

- Ones that tap into the in-vehicle communication for layer-2 communication protocols (e.g., CAN, LIN, CAN-FD, FlexRay, Ethernet, etc)
- Ones that tap into the Interfaces for Lidar, Cameras, RADAR (e.g., MIPI-CSI via SerDes, GigE Vision etc.)
- Ones that tap into sensor busses for SPI, I2C, Digital

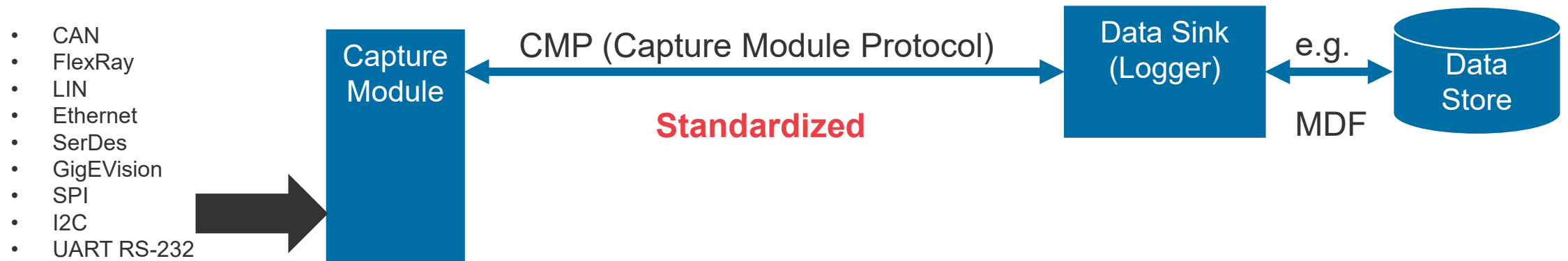

Timeline

Capture Module Protocol

Project Members

- Accurate Technologies
- Audi AG
- BMW AG
- ETAS GmbH
- Technica Engineering
- ViGEM GmbH

Project Members

- AeD Engineering GmbH
- B-plus GmbH
- dSPACE GmbH
- RA Consulting GmbH
- Vector Informatik GmbH
- X2E GmbH

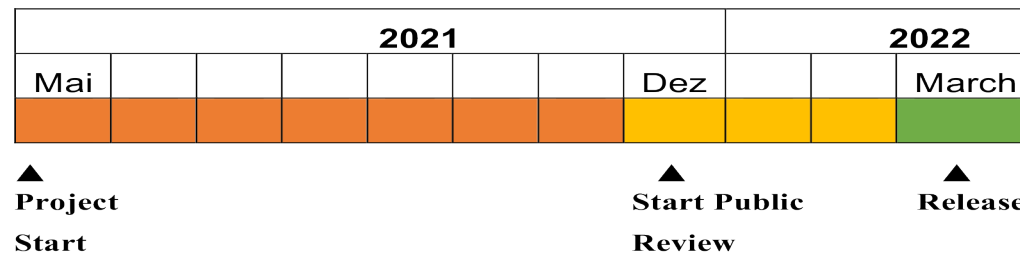

Bernd Wenzel
Senior Technical Consultant
ASAM e.V.

Phone: +49 177 7861595
Email: Bernd.Wenzel@asam.net